

# CLOUD COMPUTING AND THE CLOUD-READY DATA CENTER NETWORK



## CONTENTS

BENEFITS OF THE CLOUD-READY DATA CENTER NETWORK .....	3
GETTING READY .....	3
SIMPLIFY .....	4
SHARE .....	6
SECURE .....	6
SUMMARY .....	6
JUNIPER SOLUTION COMPONENTS .....	7
SWITCHING .....	7
ROUTING .....	7
SECURITY .....	7
OPERATING SYSTEM .....	7
NETWORK CLIENT .....	7
NETWORK MANAGEMENT .....	7
SERVICES .....	7

Cloud computing represents a new way to deliver and use services on a shared IT infrastructure and network. Previously, IT hardware and software have largely been acquired and provisioned on a business's premises. With cloud computing, the value of these same software and hardware products is delivered on demand in the form of services over a network. Cloud computing is relevant both to service providers offering cloud-based services for customers and to enterprise and public sector IT organizations that are aware of cloud computing's relevance to their own internal operations.

IT groups can now build out private clouds or augment their resources with public clouds, enabling the benefits of this powerful computing model for their data centers. To achieve optimal results, a close examination of the network is required, because in the highly connected world of virtualized applications and infrastructures, innovative networks are the foundation of cloud-ready data centers.

Juniper Networks® was founded on the vision of connecting everything and empowering everyone, engaging in a steady stream of innovations to advance the state of the art in networking for more than a decade. Establishing a relationship with a network partner like Juniper can help IT organizations reap the benefits of cloud computing and increase network effectiveness to meet current and future technological and business requirements.

## BENEFITS OF THE CLOUD-READY DATA CENTER NETWORK

Lessons learned from cloud computing can vastly improve the scale, agility and security of applications, reducing costs for delivering new services while improving user experience. Cloud services are delivered by infrastructure that is centrally managed, consolidated and enabled with virtualization. Any of the standard data center elements, such as servers, appliances, storage and other networking devices, can be contained within the cloud. By abstracting logical from physical, these elements can be arranged in resource pools that are shared securely across multiple applications, users, departments, suppliers and customers.

The resources in these pools are dynamically allocated to accommodate the changing capacity requirements of different applications and improve asset utilization levels. Consequently, cloud infrastructures are known to simplify management, reduce operating and ownership costs, and allow services to be provisioned with unprecedented speed.

Together, cloud services and the cloud infrastructure produce exceptional economies of scale, resulting in greater efficiency, agility and lower costs to deliver higher-quality services to users. Juniper has dedicated itself to building simplified, scalable, agile and secure networks with these design objectives for the cloud-ready data center.

## SUCCESS IN BUILDING A SCALABLE, CLOUD-READY DATA CENTER NETWORK REQUIRES THREE CRITICAL STEPS: (1) SIMPLIFY, (2) SHARE, AND (3) SECURE.

### GETTING READY

Success in building a scalable, cloud-ready data center network requires three critical steps: (1) simplify, (2) share, and (3) secure.

Whether you are running your internal IT as a cloud or plan to connect with public cloud services, designing a cloud-ready data center network gives you significant infrastructure advantages. Making these choices and decisions can help you lower costs, increase efficiency and keep your data center agile enough to accommodate any forthcoming changes in your business or your technology infrastructure.

### Three-Step Approach

Juniper recommends a three-step approach to make your network infrastructure cloud ready and reduce the time to implement cloud services:

**Simplify the architecture**—Consolidate siloed systems and collapse inefficient tiers, resulting in fewer devices, a smaller operational footprint, simpler design and management from a “single pane of glass.”

**Share the resources**—Segment the network into simple, logical and scalable partitions for your various applications and services with privacy, flexibility, high performance and quality of service (QoS) as primary goals. This sharing enables agility for multiple users, applications and services.

**Secure the data flows**—Integrated and virtualized security services resident in the network can provide benefits to users and applications sharing the infrastructure. Comprehensive protection secures data flows into, within and between data centers. Implement centralized management and distributed enforcement of dynamic, application- and identity-aware policies.

## Simplify

The network design that used to work for the business might not be appropriate for the new demands on IT infrastructure and, most importantly, new business requirements. Networks built on fragmented and oversubscribed tree structures have problems with scaling and consistent performance (Figure 1). Design and management complexity and costs increase exponentially as more devices are added.

Juniper Networks' vision for the ultimate simplification of the data center is the previously announced Project Stratus, replacing multiple devices with a single logical switch (Figure 2). Guided by this vision, Juniper offers a dramatically streamlined architecture today for a cloud-ready data center network with reduced complexity, improved efficiencies and lower operational, capital and environmental costs.

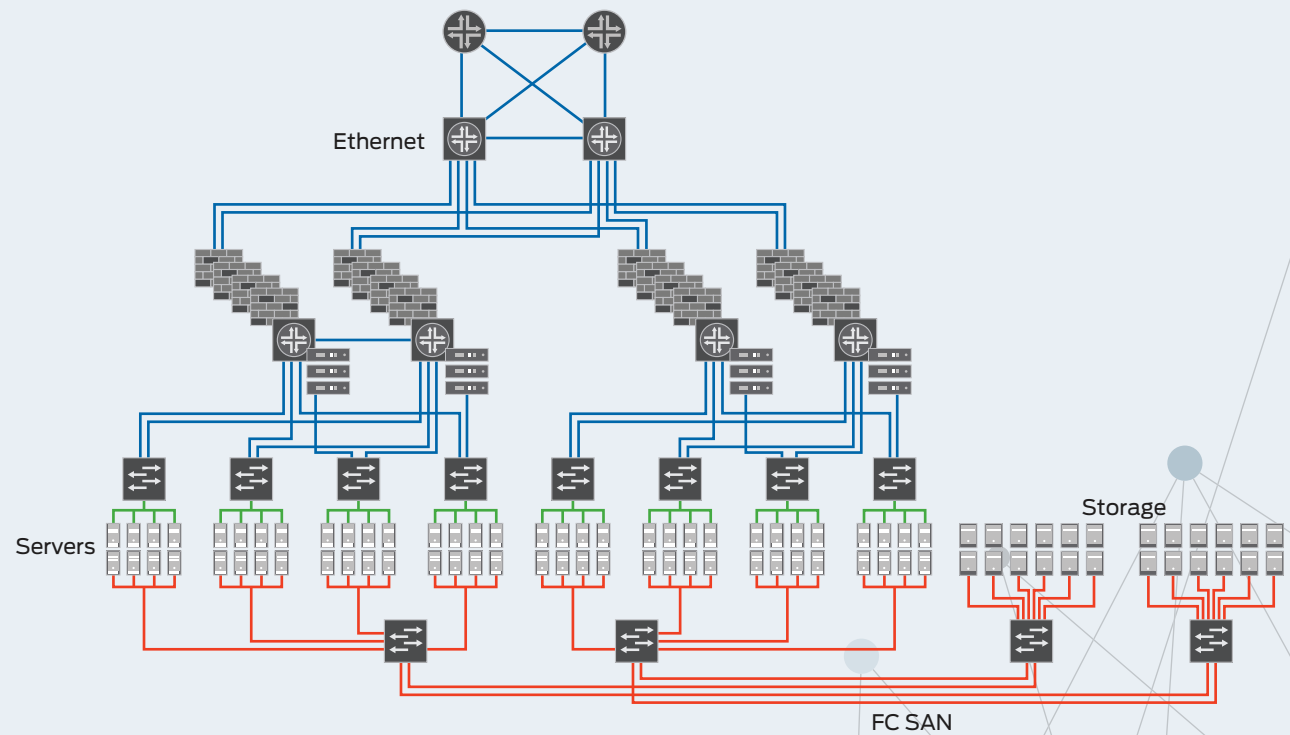

Figure 1: The legacy network.

Juniper Networks helps organizations simplify their cloud-ready data centers with an innovative industry-leading product portfolio and solutions for important network design challenges. Multiple switching tiers are collapsed in Juniper's simplified design, requiring fewer devices and interconnections.

#### Layer Consolidation

Juniper simplifies virtual-server deployment with Virtual Chassis technology (gray shadowed devices in Figure 3). When placed in the access tier, the Juniper Networks EX4200 Ethernet Switch reduces configuration burdens in the network and measurably improves performance for server-to-server communications in service-oriented architecture, Web services and other distributed application designs.

#### Edge Service Consolidation and Management

At a data center's edge, where connections to other data centers and networks occur over the WAN, the Internet or a partner's network, the number of deployed devices can be consolidated into fewer, more agile and scalable devices with Juniper. This consolidation simplifies the management and control of the connections and lowers operational cost. Juniper Networks M Series Multiservice Edge Routers and MX Series 3D Universal Edge Routers are powerful, reliable and the most scalable for the intelligent-edge and inter-data center mobility.

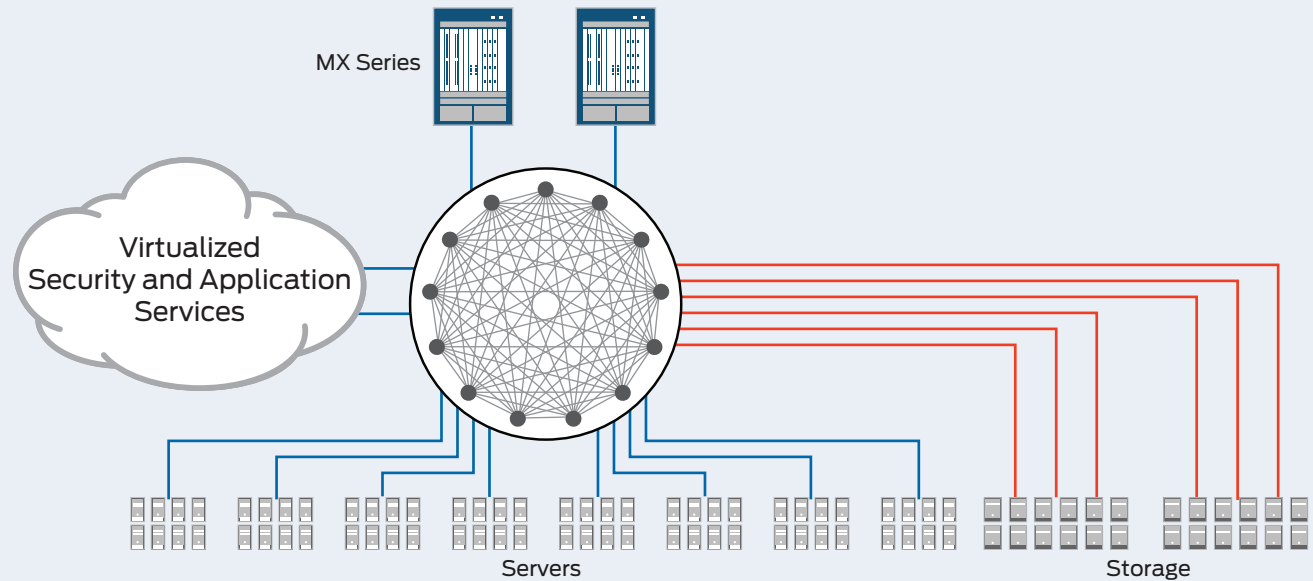

Figure 2: The Stratus Project – Juniper's vision for a single data center fabric.

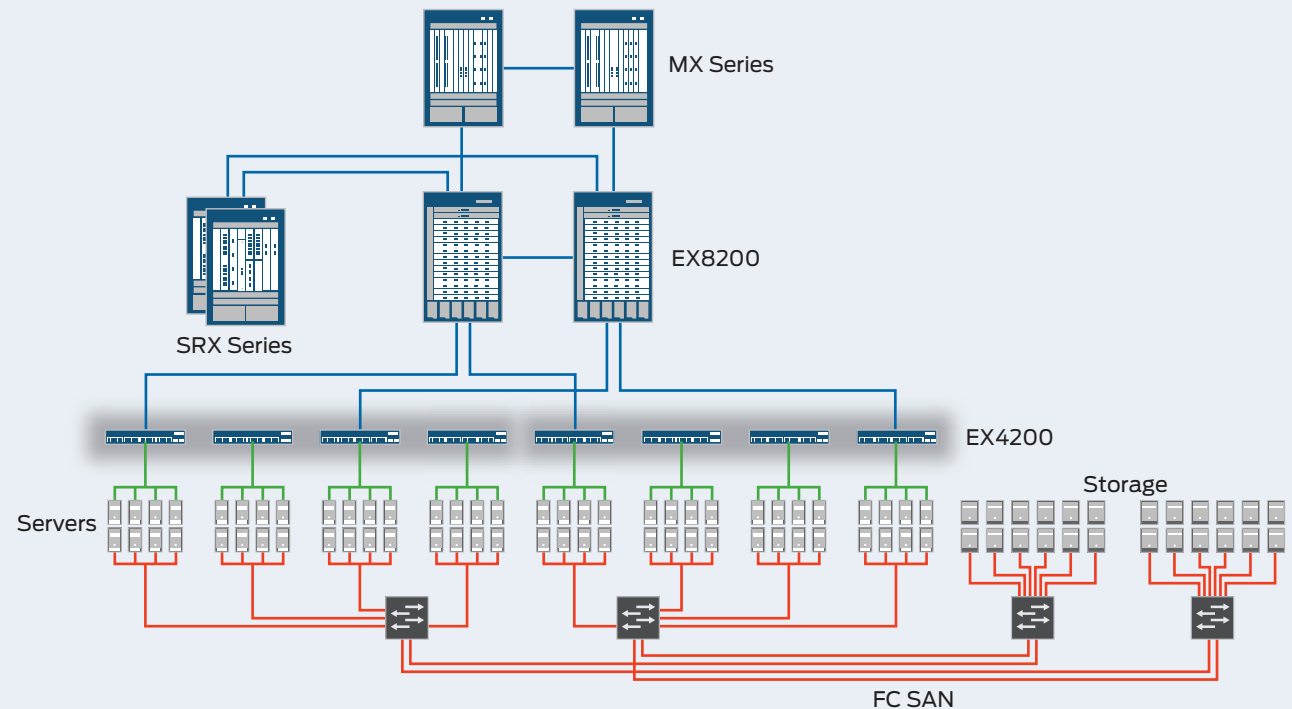

Figure 3: Juniper's data center solution today.

## Service Consolidation

Network-based security services—intrusion detection, attack prevention, encryption, monitoring—can be consolidated into highly scalable virtualized security platforms to reduce security “sprawl.” The Juniper Networks SRX Series Services Gateways can condense previously siloed security platforms by a factor of 5 to 1. The SRX Series enables rapid provisioning and simplified operation of multiple security controls for elastic scaling of security services across physical and logical platforms.

## Unified Management

By using a common operating system (for example, Juniper Networks Junos® operating system) and a unified management system, Juniper is able to significantly simplify configuration and problem management for multiple applications and user groups. These gains are crucial to maintaining service levels and flexibility in IT infrastructure while following the constant business imperative of doing more with less.

## Share

Economic and agility imperatives of the cloud-ready data center require network resources to be allocated, expanded and reallocated efficiently at scale. The uniquely architected Juniper platforms deliver the agility and scaling required by virtualizing network configurations, segmenting services into logical domains and using industry-leading hardware designs to scale without complexity. With a large pool of resources to draw on, customers can efficiently partition those resources to meet service requirements, remain flexible and ensure operational performance, security and control.

## Resource Allocation

Juniper’s recommended approach to sharing the network revolves around aligning capacities, bandwidth, priorities and availability goals with application requirements using technologies based on standards and simplified policies.

Starting with Juniper Networks Virtual Chassis technology, available with the EX4200 line of switches, organizations can deploy more Layer 2 VLANs with fewer devices. In each of Juniper’s routing and switching lines, customers have unmatched scale and agility in processing access control lists that forward traffic according to previously established rules for designated types, rates and packet sizes. Juniper security services and policies nest VLANs within logical zones for security segmentation. With Juniper’s carrier-grade, scalable MPLS and VPLS technologies, VPNs can be used to extend zones while VLANs can be stretched across data centers or pods for more flexible shared links to the cloud (Figure 4).

## Secure

Security administrators must secure client-to-server traffic as well as traffic between physical and virtual servers, applications and other data centers. The increased access and sophistication of security threats in a cloud-ready data center requires expanded security protection capabilities. Appropriate security policies affect service availability of business-critical applications and operations.

To address these challenges, security services should be consolidated and virtualized to compliment the simplification and sharing of the cloud-ready data center network. This approach enhances the flexibility and efficiency of the entire security solution.

Juniper Networks has developed high-performance, cloud-enabled virtualized security services, which meet today’s security and performance requirements while accommodating future on-demand

growth. Security services, such as application monitoring, stateful firewalls, intrusion detection and prevention systems, and VPNs, are all consolidated on a platform that flexibly and dynamically assigns resources as needed. Juniper provides best-practices guides for security to minimize risk and speed time to implementation when configuring security solutions for cloud-ready data centers.

## SUMMARY

Many organizations can benefit from cloud-ready data center networks, whether building a private cloud network for internal purposes, connecting to public cloud services or preparing to connect to public cloud services in the future. Juniper Networks, as a partner with demonstrable experience, can help organizations reduce complexity and overall costs in IT while accelerating delivery of services to users in a secure cloud network.

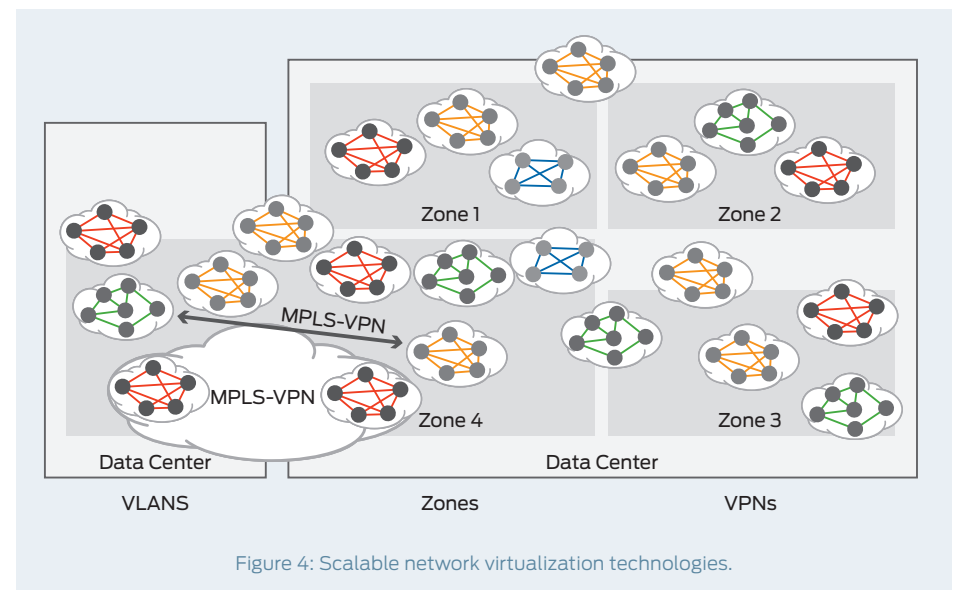

Figure 4: Scalable network virtualization technologies.

## JUNIPER SOLUTION COMPONENTS

### Switching

**EX Series Ethernet Switches:** Deliver unmatched scale and performance for L2 and L3 data center networks. The high-density, high-performance Juniper Networks EX8200 Ethernet Switches support data center and cloud computing environments. Virtual Chassis technology enables up to 10 interconnected EX4200 switches to operate as a single device, reducing management overhead.

### Routing

**M Series Multiservice Edge Routers:** Combine best-in-class integrated virtualization and traffic management with unmatched reliability, stability, security and service richness to connect the cloud-ready data center to the WAN.

**MX Series 3D Universal Edge Routers:** Provide Ethernet switching capabilities coupled with the carrier-class routing features customers expect from Juniper to support advanced virtualization of network infrastructures and traffic management between data centers and WANs.

### Security

**SRX Series Services Gateways:** Combine routing, switching, application services, and user- and application-aware security within a single device.

**Unified Access Control:** Provides powerful identity- and role-based access control that increases agility in service deployment and overall quality of experience. UAC can be deployed within a data center or across an extended enterprise to protect networks and applications.

**SA Series SSL VPN Appliances:** Provide scalable, simplified and secure remote access from multiple remote networks and platforms (SSL VPN) to data center resources.

### Operating System

**Junos OS:** Integrates routing, switching, and security services, and offers the power of one operating system to reduce complexity, achieve operational excellence and deliver dynamic services with lower TCO.

### Network Client

**Junos Pulse:** A dynamic, standards-based multiservice network client delivering integrated connectivity, access, acceleration, and security anytime/anywhere while drastically simplifying the user experience.

### Network Management

**Network and Security Manager:** Provides a single pane of management for the entire network infrastructure, including routing, switching and security devices.

**STRM Series Security Threat Response Managers:** Collect events and alerts from different Juniper and third-party products, aggregating and delivering them to an enterprisewide threat management view.

### Services

**J-Care Technical Services:** A family of support services, J-Care Technical Services offers unlimited access to Juniper's support centers online or by telephone, immediate software updates and hardware replacement options. J-Care Efficiency, Continuity and Agility services add the automation elements of Advanced Insight Services (AIS), which reduces operating expenses and simplifies operations.

#### **Corporate and Sales Headquarters**

Juniper Networks, Inc.  
1194 North Mathilda Avenue  
Sunnyvale, CA 94089 USA  
Phone: 888.JUNIPER (888.586.4737)  
or 408.745.2000  
Fax: 408.745.2100  
www.juniper.net

#### **APAC Headquarters**

Juniper Networks (Hong Kong)  
26/F, Cityplaza One  
1111 King's Road  
Taikoo Shing, Hong Kong  
Phone: 852.2332.3636  
Fax: 852.2574.7803

#### **EMEA Headquarters**

Juniper Networks Ireland  
Airside Business Park  
Swords, County Dublin, Ireland  
Phone: 35.31.8903.600  
EMEA Sales: 00800.4586.4737  
Fax: 35.31.8903.601

Copyright 2009 Juniper Networks, Inc.  
All rights reserved. Juniper Networks, the Juniper Networks logo, Junos, NetScreen, and ScreenOS are registered trademarks of Juniper Networks, Inc. in the United States and other countries. All other trademarks, service marks, registered marks, or registered service marks are the property of their respective owners. Juniper Networks assumes no responsibility for any inaccuracies in this document. Juniper Networks reserves the right to change, modify, transfer, or otherwise revise this publication without notice.

 Printed on recycled paper